

VS-1PT-EC Temperature Input Expansion Card

The VS-1PT-EC Temperature Input Expansion Card can receive external 1 channel of PT-100 Platinum RTD signal input, and converts that into temperature related digital value. When the END instruction is executed, the VS Main Unit reads out temperature conversion data from the VS-1PT-EC card and stores the value to respective EC card register. Thus, it provides the reference data for digital monitoring or control.

The VS-1PT-EC Temperature Input Expansion Card is non-isolated. Please read following instructions before use.

- Product Exterior

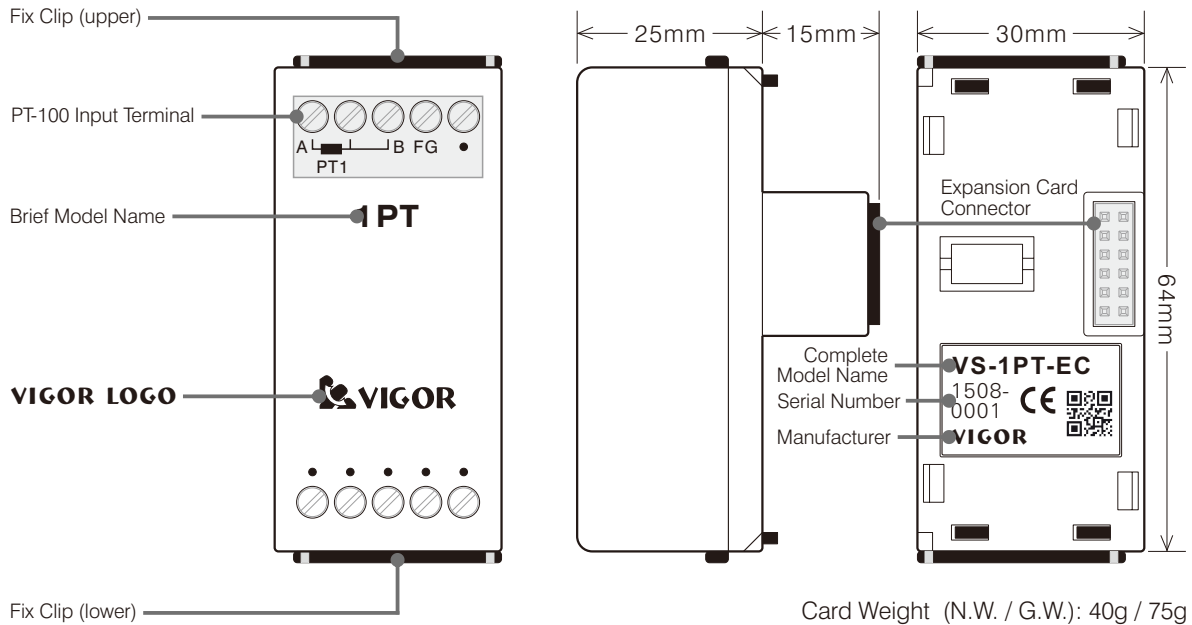

- Product Specification

Basic Specification

Item	Specification
Power Consumption	DC5V 15mA, DC12V 0mA (from PLC Main Unit)

Performance Specification of Temperature Input

Item	Specification
Sensor Type	PT-100, Platinum resistance thermometer (RTD), 3-Wire, 100 Ω @ 0 °C , 3850 PPM/°C
Measurable Range	-200 °C ~ 850 °C (-328 °F ~ 1562 °F)
Converted Value	The measurement results are indicated by the unit of 0.1 °C or 0.1 °F .
Resolution	0.1 °C (0.18 °F)
Overall Accuracy	± 1% (Overall Max.)
Response Time	25 ms, the temperature values will be renewed at the END instruction.
Isolation Method	No isolation between PLC and PT-100 input

● EC Card Register (Simple Code) Related to VS-1PT-EC

EC1	EC2	EC3	Component Description
EC1D0	EC2D0	EC3D0	To select the frequency of power noise to be filtered out. 0: 60Hz, 1: 50Hz; other values: 60Hz. Reduce the influence of noise from power lines. Always set the value as 1 for 50Hz AC system.
EC1D1	EC2D1	EC3D1	To assign the unit of temperature measurement. 0: °C; 1: °F; other values: °C.
EC1D2	EC2D2	EC3D2	Converted temperature value of PT1, with unit as 0.1 °C or 0.1 °F.
EC1D6	EC2D6	EC3D6	To set the average times of PT1. Usable set value is 1~32767; other values = 1.
EC1D17	EC2D17	EC3D17	Status and error flag
EC1D18	EC2D18	EC3D18	Identification code: K107 (If code = K240, means connecting error between Main Unit and card)
EC1D19	EC2D19	EC3D19	The version number of this card. (the content value □□ indicates Ver. □.□)

Status and Error Flag:

b15~b5	b4	b3	b2	b1	b0
--------	----	----	----	----	----

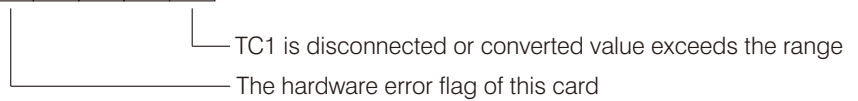

● External Wiring

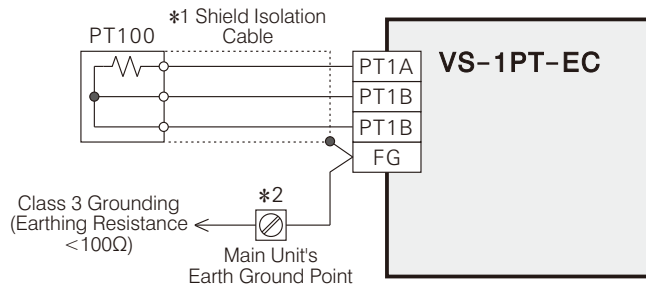

- *1: Please use the shield isolation cable for temperature input. Must keep the signal cable away from any power line (including the power of motor, valve or contactor) to prevent external interference or card damage.
- *2: First, please connect the end of the covering layer of shielded cable to the FG terminal. Then, connect that FG to the earth ground point of Main Unit. After that, make use of class 3 grounding for the point.

● Example Program

The VS-1PT-EC is installed at the EC2, the average times of PT1 is set to be 10 times.
The input converted value of PT1 is stored at D100.

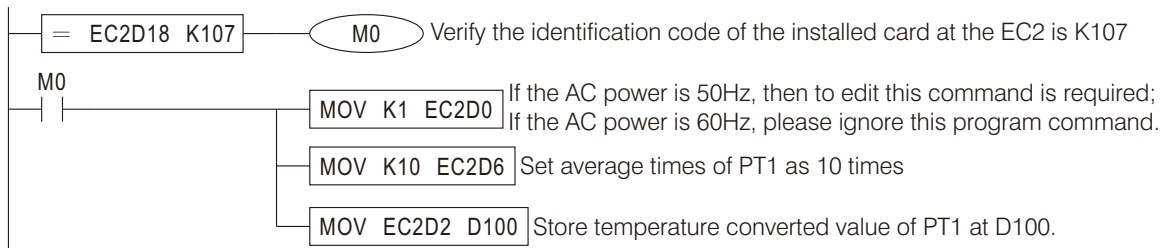

VS-2PT-EC Temperature Input Expansion Card

The VS-2PT-EC Temperature Input Expansion Card can receive external 2 channels of PT-100 Platinum RTD signal input, and converts those into temperature related digital values. When the END instruction is executed, the VS Main Unit reads out temperature conversion data from the VS-2PT-EC card and stores the values to respective EC card registers. Thus, it provides the reference data for digital monitoring or control.

The VS-2PT-EC Temperature Input Expansion Card is non-isolated. Please read following instructions before use.

- Product Exterior

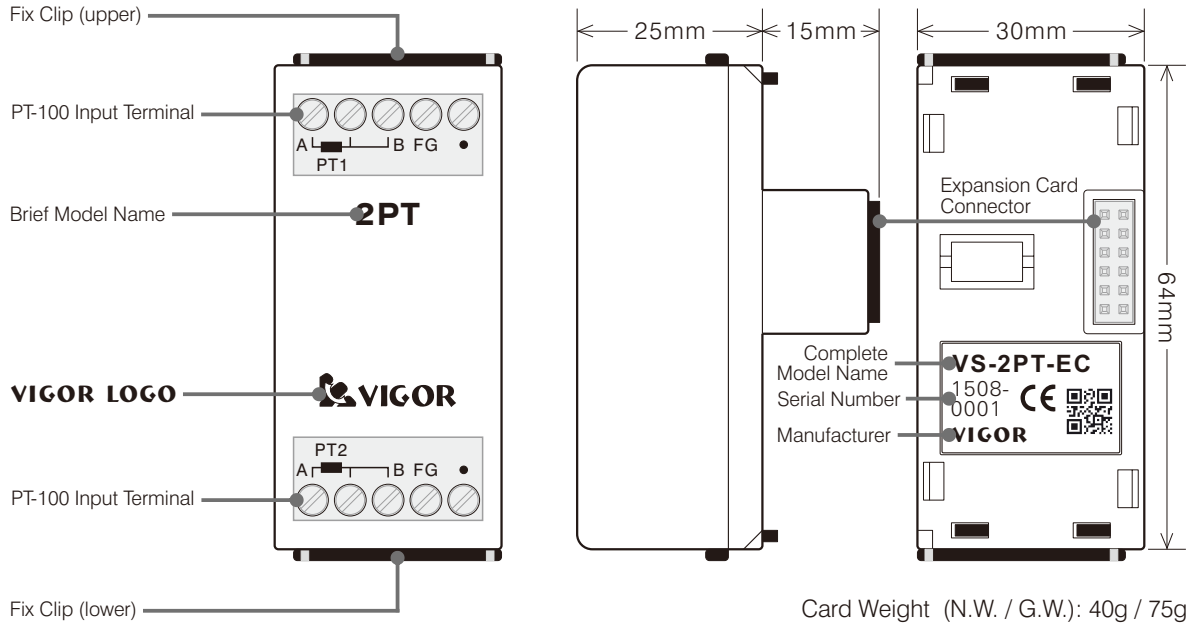

- Product Specification

Basic Specification

Item	Specification
Power Consumption	DC5V 22mA, DC12V 0mA (from PLC Main Unit)

Performance Specification of Temperature Input

Item	Specification
Sensor Type	PT-100, Platinum resistance thermometer (RTD), 3-Wire, 100 Ω @ 0 °C , 3850 PPM/°C
Measurable Range	-200 °C ~ 850 °C (-328 °F ~ 1562 °F)
Converted Value	The measurement results are indicated by the unit of 0.1 °C or 0.1 °F .
Resolution	0.1 °C (0.18 °F)
Overall Accuracy	± 1% (Overall Max.)
Response Time	25 ms, the temperature values will be renewed at the END instruction.
Isolation Method	No isolation between PLC and PT-100 inputs; no isolation between PT-100 input channels

● EC Card Register (Simple Code) Related to VS-2PT-EC

EC1	EC2	EC3	Component Description
EC1D0	EC2D0	EC3D0	To select the frequency of power noise to be filtered out. 0: 60Hz, 1: 50Hz; other values: 60Hz. Reduce the influence of noise from power lines. Always set the value as 1 for 50Hz AC system.
EC1D1	EC2D1	EC3D1	To assign the unit of temperature measurement. 0: °C ; 1: °F ; other values: °C .
EC1D2	EC2D2	EC3D2	Converted temperature value of PT1, with unit as 0.1 °C or 0.1 °F .
EC1D3	EC2D3	EC3D3	Converted temperature value of PT2, with unit as 0.1 °C or 0.1 °F .
EC1D6	EC2D6	EC3D6	To set the average times of PT1.
EC1D7	EC2D7	EC3D7	To set the average times of PT2.
EC1D17	EC2D17	EC3D17	Status and error flag.
EC1D18	EC2D18	EC3D18	Identification code: K108 (If code = K240, means connecting error between Main Unit and card)
EC1D19	EC2D19	EC3D19	The version number of this card. (the content value □□ indicates Ver. □.□)

Status and Error Flag:

b15~b5	b4	b3	b2	b1	b0
--------	----	----	----	----	----

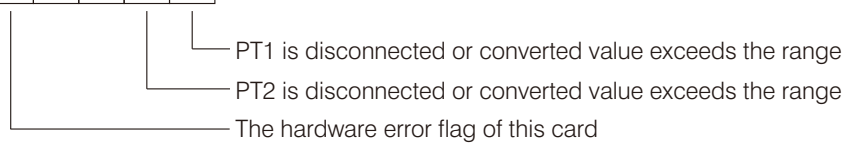

● External Wiring

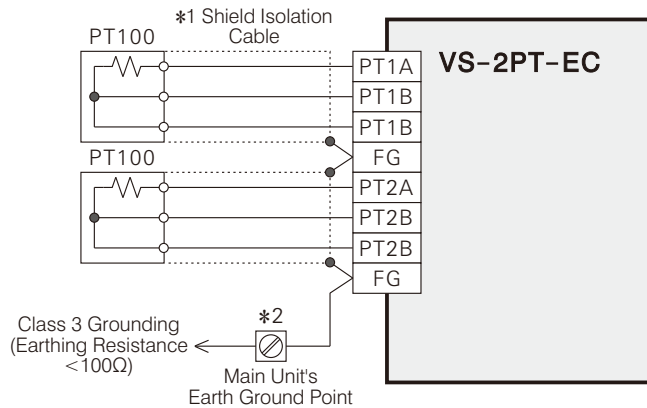

*1: Please use the shield isolation cable for every temperature input. Must keep the signal cable away from any power line (including the power of motor, valve or contactor) to prevent external interference or card damage.

*2: First, please connect the end of the covering layer of shielded cable to the FG terminal. Then, connect those FGs to the earth ground point of Main Unit. After that, make use of class 3 grounding for the point.

● Example Program

The VS-2PT-EC is installed at the EC2, the average times of PT1 is set to be 5 times and the average times of PT2 is set to be 20 times.

The input converted value of PT1 is stored at D100; the input converted value of PT2 is stored at D200.

