

# VS-2TC-EC Temperature Input Expansion Card

The VS-2TC-EC Temperature Input Expansion Card can receive external 2 channels of thermocouple signal input, and converts those into temperature related digital values. When the END instruction is executed, the VS Main Unit reads out temperature conversion data from the VS-2TC-EC card and stores the values to respective EC card registers. Thus, it provides the reference data for digital monitoring or control.

Since between the input channels are non-isolated, the isolated (ungrounded) thermocouple sensors are required. Thus, the VS-2TC-EC Temperature Input Expansion Card is non-isolated. Please read following instructions before use.

## ● Product Exterior

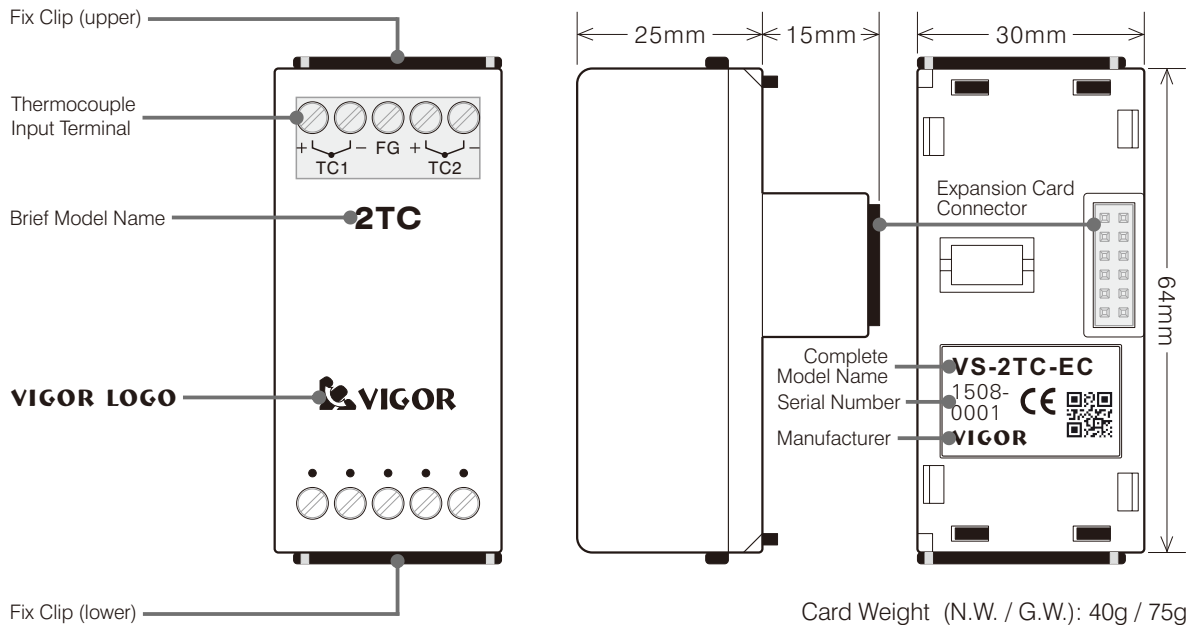

## ● Product Specification

### Basic Specification

Item	Specification
Power Consumption	DC5V 7mA, DC12V 0mA (from PLC Main Unit)

### Performance Specification of Temperature Input

Item	Specification	
Sensor Type	K, J, R, S, T, E, B or N type isolated (ungrounded) thermocouple	
Measurable Range	K	-200 °C ~ 1200 °C (-328 °F ~ 2192 °F)
	J	-160 °C ~ 1200 °C (-256 °F ~ 2192 °F)
	R	0 °C ~ 1768 °C (32 °F ~ 3214.4 °F)
	S	0 °C ~ 1768 °C (32 °F ~ 3214.4 °F)
	T	-220 °C ~ 400 °C (-364 °F ~ 752 °F)
	E	-220 °C ~ 1000 °C (-364 °F ~ 1832 °F)
	B	300 °C ~ 1800 °C (572 °F ~ 3272 °F)
	N	-200 °C ~ 1300 °C (-328 °F ~ 2372 °F)
Converted Value	The measurement results are indicated by the unit of 0.1 °C or 0.1 °F.	
Resolution	0.2 °C ~ 0.3 °C (0.36 °F ~ 0.54 °F)	
Overall Accuracy	± 1% (Overall Max.) ± 1 °C	
Response Time	100 ms, the temperature values will be renewed at the END instruction.	
Isolation Method	No isolation between PLC and input channels. No isolation between input channels. Please use the isolated (ungrounded) thermocouple sensors.	

● EC Card Register (Simple Code) Related to VS-2TC-EC

EC1	EC2	EC3	Component Description
EC1D0	EC2D0	EC3D0	To assign the thermocouple types for TC1~TC2.
EC1D1	EC2D1	EC3D1	To assign the unit of temperature measurement. 0:°C; 1:°F; other values: °C.
EC1D2	EC2D2	EC3D2	Converted temperature value of TC1, with unit as 0.1 °C or 0.1 °F.
EC1D3	EC2D3	EC3D3	Converted temperature value of TC2, with unit as 0.1 °C or 0.1 °F.
EC1D6	EC2D6	EC3D6	To set the average times of TC1
EC1D7	EC2D7	EC3D7	To set the average times of TC2
EC1D17	EC2D17	EC3D17	Status and error flag
EC1D18	EC2D18	EC3D18	Identification code: K105 (If code = K240, means connecting error between Main Unit and card)
EC1D19	EC2D19	EC3D19	The version number of this card. (the content value □□ indicates Ver. □.□)

Assign Thermocouple Type:

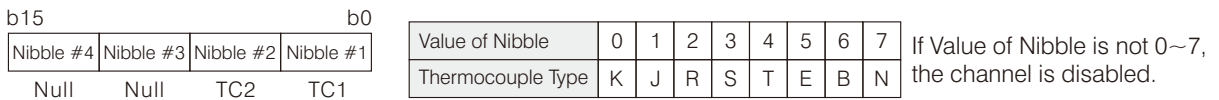

Example: If a VS-2TC-EC is installed at the EC1, and its EC1D0 is set to be H0010, then TC1: K Type of thermocouple input, TC2: J Type thermocouple input.

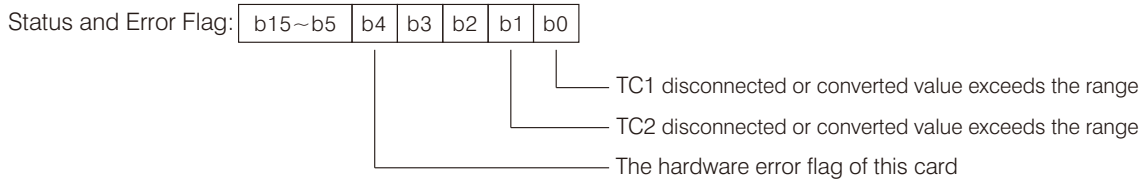

● External Wiring

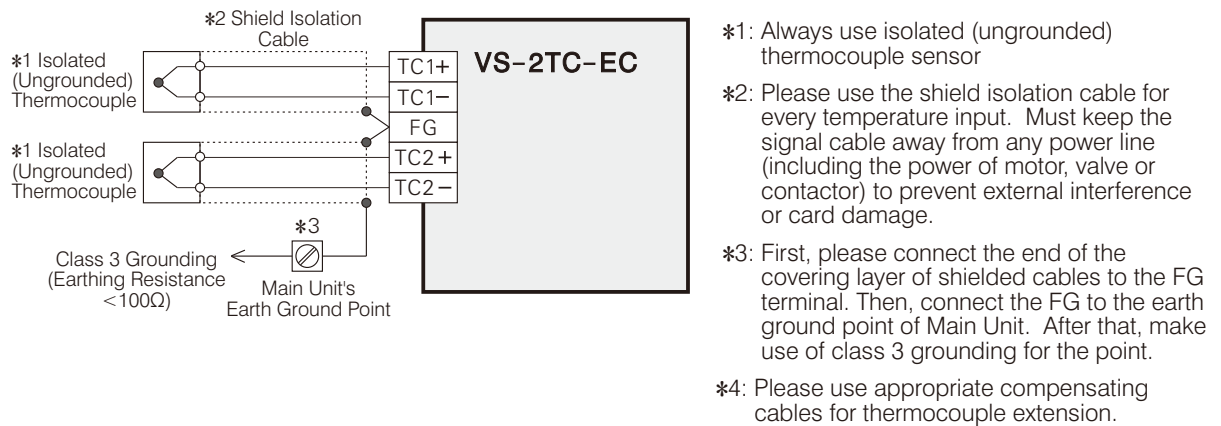

● Example Program

The VS-2TC-EC is installed at the EC2, its TC1 is for the K Type thermocouple and TC2 is for the J Type thermocouple; the average times of each temperature input is set to be 10 times. The input converted values of TC1~TC2 are sequentially stored at D100~D101.

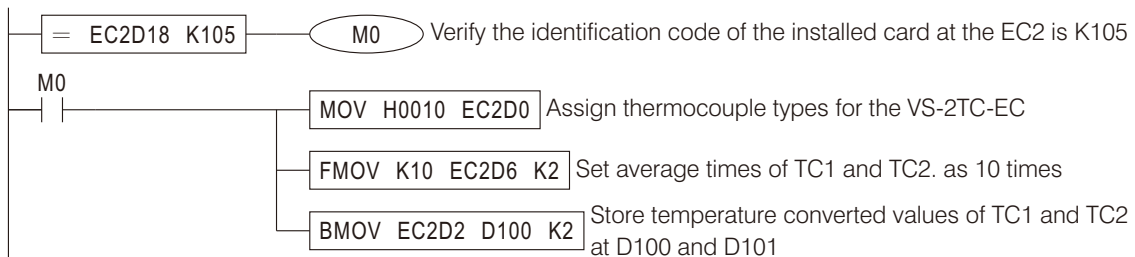

# VS-4TC-EC Temperature Input Expansion Card

The VS-4TC-EC Temperature Input Expansion Card can receive external 4 channels of thermocouple signal input, and converts those into temperature related digital values. When the END instruction is executed, the VS Main Unit reads out temperature conversion data from the VS-4TC-EC card and stores the values to respective EC card registers. Thus, it provides the reference data for digital monitoring or control.

Since between the input channels are non-isolated, the isolated (ungrounded) thermocouple sensors are required. Thus, the VS-4TC-EC Temperature Input Expansion Card is non-isolated. Please read following instructions before use.

## • Product Exterior

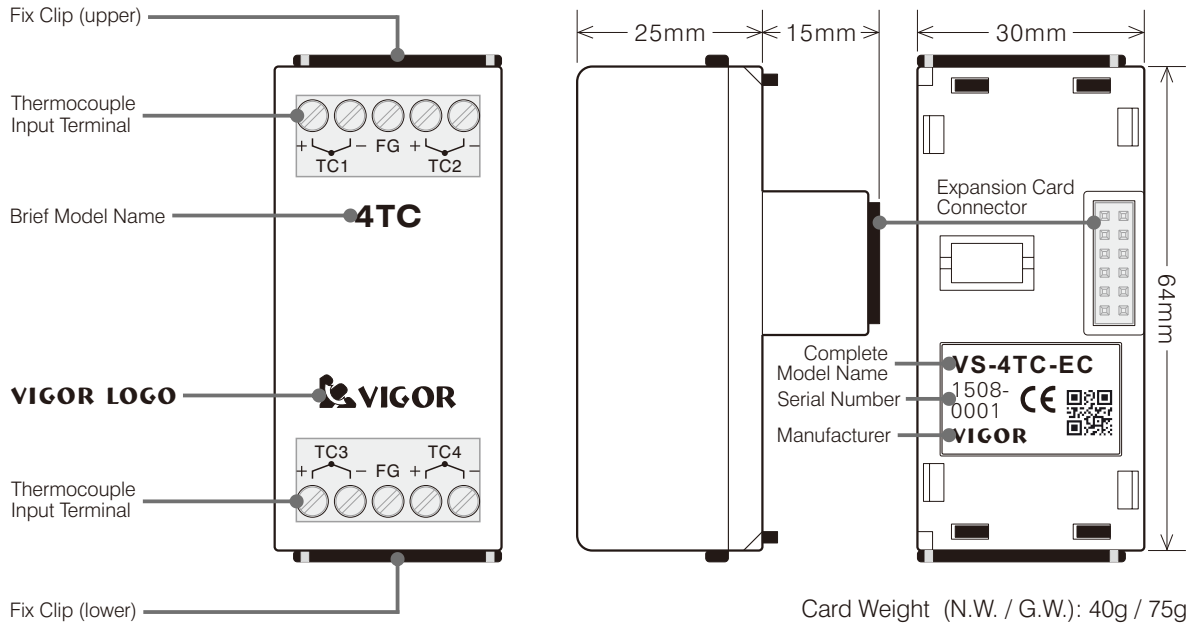

## • Product Specification

### Basic Specification

Item	Specification
Power Consumption	DC5V 7mA, DC12V 0mA (from PLC Main Unit)

### Performance Specification of Temperature Input

Item	Specification	
Sensor Type	K, J, R, S, T, E, B or N type isolated (ungrounded) thermocouple	
Measurable Range	K	-200 °C ~ 1200 °C (-328 °F ~ 2192 °F)
	J	-160 °C ~ 1200 °C (-256 °F ~ 2192 °F)
	R	0 °C ~ 1768 °C (32 °F ~ 3214.4 °F)
	S	0 °C ~ 1768 °C (32 °F ~ 3214.4 °F)
	T	-220 °C ~ 400 °C (-364 °F ~ 752 °F)
	E	-220 °C ~ 1000 °C (-364 °F ~ 1832 °F)
	B	300 °C ~ 1800 °C (572 °F ~ 3272 °F)
	N	-200 °C ~ 1300 °C (-328 °F ~ 2372 °F)
Converted Value	The measurement results are indicated by the unit of 0.1 °C or 0.1 °F	
Resolution	0.2 °C ~ 0.3 °C (0.36 °F ~ 0.54 °F)	
Overall Accuracy	± 1% (Overall Max.) ± 1 °C	
Response Time	100 ms, the temperature values will be renewed at the END instruction.	
Isolation Method	No isolation between PLC and input channels. No isolation between input channels. Please use the isolated (ungrounded) thermocouple sensors.	

● EC Card Register (Simple Code) Related to VS-4TC-EC

EC1	EC2	EC3	Component Description
EC1D0	EC2D0	EC3D0	To assign the thermocouple types for TC1~TC4.
EC1D1	EC2D1	EC3D1	To assign the unit of temperature measurement. 0:°C; 1:°F; other values:°C.
EC1D2	EC2D2	EC3D2	Converted temperature value of TC1, with unit as 0.1 °C or 0.1 °F.
EC1D3	EC2D3	EC3D3	Converted temperature value of TC2, with unit as 0.1 °C or 0.1 °F.
EC1D4	EC2D4	EC3D4	Converted temperature value of TC3, with unit as 0.1 °C or 0.1 °F.
EC1D5	EC2D5	EC3D5	Converted temperature value of TC4, with unit as 0.1 °C or 0.1 °F.
EC1D6	EC2D6	EC3D6	To set the average times of TC1
EC1D7	EC2D7	EC3D7	To set the average times of TC2
EC1D8	EC2D8	EC3D8	To set the average times of TC3
EC1D9	EC2D9	EC3D9	To set the average times of TC4
EC1D17	EC2D17	EC3D17	Status and error flag
EC1D18	EC2D18	EC3D18	Identification code: K106 (If code = K240, means connecting error between Main Unit and card)
EC1D19	EC2D19	EC3D19	The version number of this card. (the content value □□ indicates Ver. □.□)

To appoint the types of thermocouples:



Example: If a VS-4TC-EC is installed at the EC1, and its EC1D0 is set to be H8100, then TC1 & TC2: K Type of thermocouple input, TC3: J Type thermocouple input, TC4: disabled

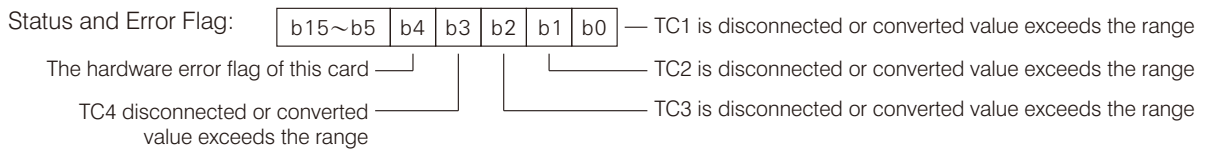

● External Wiring

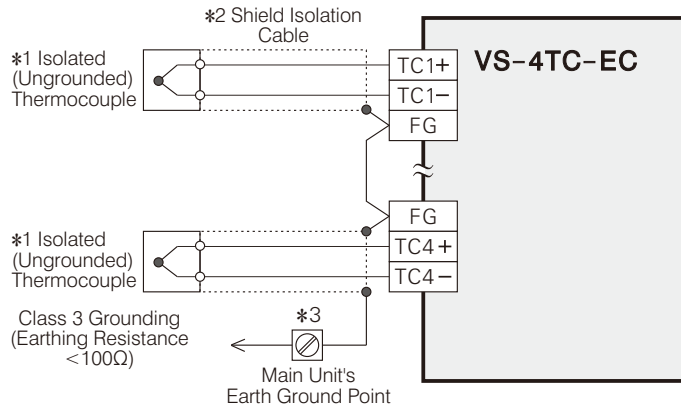

- \*1: Always use isolated (ungrounded) thermocouple sensor
- \*2: Please use the shield isolation cable for every temperature input. Must keep the signal cable away from any power line (including the power of motor, valve or contactor) to prevent external interference or card damage.
- \*3: First, please connect the end of the covering layer of shielded cables to the FG terminal. Then, connect those FGs to the earth ground point of Main Unit. After that, make use of class 3 grounding for the point.
- \*4: Please use appropriate compensating cables for thermocouple extension.

● Example Program

The VS-4TC-EC is installed at the EC2, its TC1 is for the K Type thermocouple and TC2~TC4 are for the J Type thermocouples; the average times of each temperature input is set to be 10 times. The input converted values of TC1~TC4 are sequentially stored at D100~D103.

