

VS-2DA-EC Analog Output Expansion Card

The VS-2DA-EC Analog Output Expansion Card can generate 2 channels of external voltage or current signal output, those are converted from the sources of 12-bit digital set values. When the END instruction is executed, the VS Main Unit sends out source data to the VS-2DA-EC card and stores the values to respective EC card registers then its DA circuit converts the data to analog outputs. Thus, it provides two analog signal outputs from digital set values to control the external loads.

The VS-2DA-EC Analog Output Expansion Card is non-isolated. Please read following instructions before use.

• Product Exterior

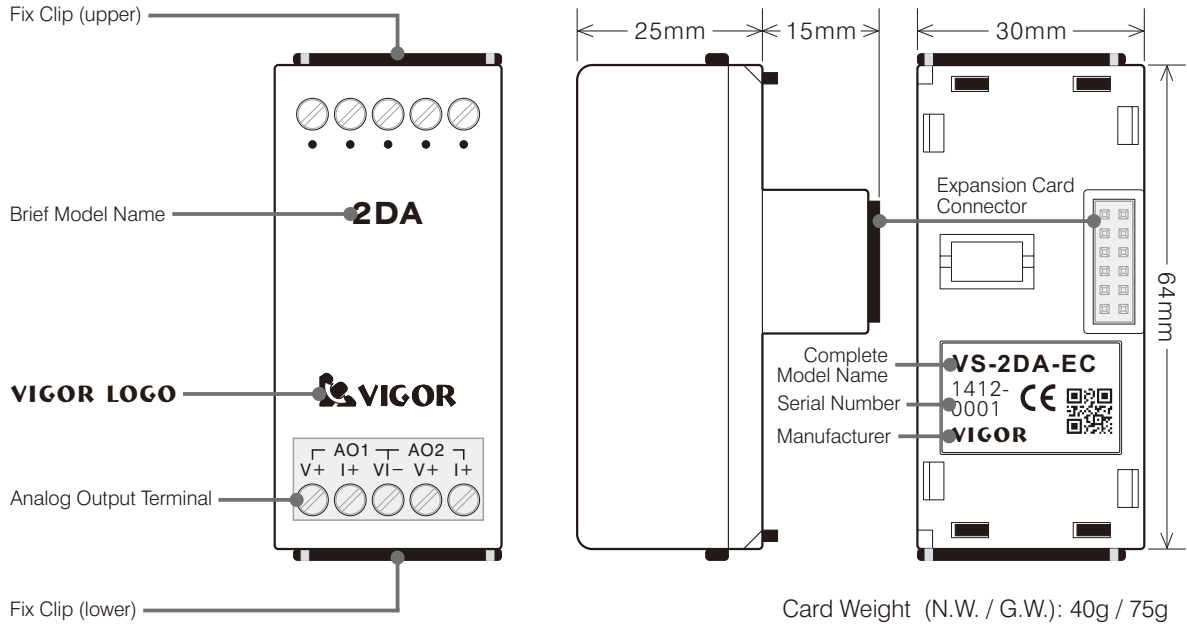

• Product Specification

Basic Specification

| Item | Specification |
|-------------------|--|
| Power Consumption | DC5V 15mA, DC12V 60mA (from PLC Main Unit) |

Analog Output Specification

| Item | Voltage Output Spec. | Current Output Spec. | |
|--------------------------|--|----------------------|------------|
| | The voltage or current output is selected by EC card mode register and makes the output through specific terminals | | |
| Analog Output Range | 0~10V | 4~20mA | 0~20mA |
| Digital Set Range | 0~4000 | 0~3200 | 0~4000 |
| Load Resistance | 500Ω~1MΩ | 500Ω(Max.) | 500Ω(Max.) |
| Resolution | 2.5mV | 5μA | 5μA |
| Overall Accuracy | ± 1.5% (Overall Max.) | | |
| Response Time | 15 μs × (the No. of enabled AO CHs) ; the AO values will be sent at the END instruction. | | |
| Isolation Method | No isolation between PLC and outputs; no isolation between output channels | | |
| Conversion Curve Diagram | | | |

● EC Card Register (Simple Code) Related to VS-2DA-EC

| EC1 | EC2 | EC3 | Component Description |
|--------|--------|--------|---|
| EC1D10 | EC2D10 | EC3D10 | To assign the analog output modes of AO1~AO2. |
| EC1D11 | EC2D11 | EC3D11 | Digital set value for AO1, 0~4000 or 0~3200. |
| EC1D12 | EC2D12 | EC3D12 | Digital set value for AO2, 0~4000 or 0~3200. |
| EC1D18 | EC2D18 | EC3D18 | Identification code: K102 (If code = K240, means connecting error between Main Unit and card) |
| EC1D19 | EC2D19 | EC3D19 | The version number of this card. (the content value □□ indicates Ver. □.□) |

To appoint the modes of analog outputs:

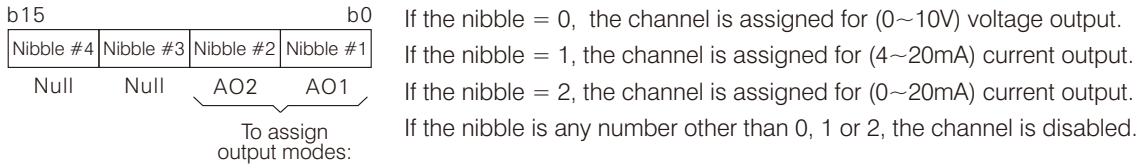

Example: If a VS-2DA-EC is installed at the EC1, and its EC1D10 is set to be H10, then
 AO1: voltage output (0~10V) AO2: current output (4~20mA)

● External Wiring

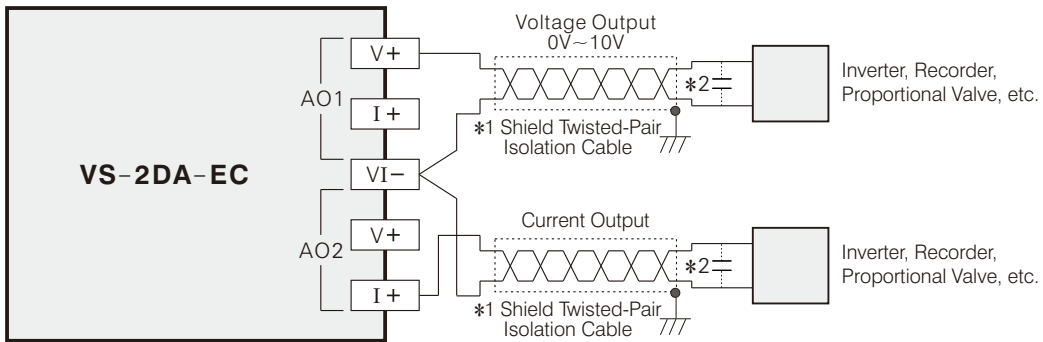

- *1: Please use the Shield Twisted-Pair isolation cable for every analog output channel and ground the cable's shield (class 3 grounding, grounding resistance < 100Ω). Must keep the signal cable away from any power line (including the power of motor, valve or contactor) to prevent external interference or card damage.
- *2: If the reading value of voltage/current signal is fluctuating or with electrically induced noise on the external wiring, please parallel connect a smoothing capacitor (0.1 μF~0.47 μF, 25V) between the input terminals.
- *3: For every analog output channel, either voltage or current output can be used but not both at the same time.

● Example Program

Assume that VS-2DA-EC is installed at the EC2, its AO1 is used for 0~10V output, AO2 is used for 4~20mA output. Output digital set values of AO1~AO2 are sequentially stored at D7000~D7001.

