

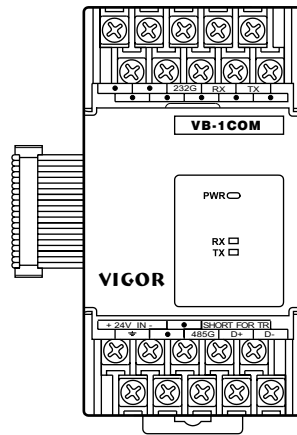

VIGOR

PROGRAMMABLE LOGICAL CONTROLLERS

VIGOR ELECTRIC CORP.



USER'S MANUAL

VB-1COM Serial INTERFACE BLOCK

VB-1COM Serial Interface Block

Foreword

- This manual contains text, diagrams and explanations which will guide the reader in the correct installation and operation of the VB-1COM. It should be read and understood before attempting to install or use the unit.
- If in doubt at any stage during the installation of the VB-1COM Serial Interface Block always consult a professional electrical engineer who is qualified and trained to the local and national standards.
If in doubt about the operation or use of the VB-1COM Serial Interface Block please consult the nearest VIGOR ELECTRIC CORP. distributor.
- This manual is subject to change without notice.

VB-1COM Serial Interface Block

Under no circumstances will VIGOR ELECTRIC CORP. be liable responsible for any consequential damage that may arise as a result of the installation or use of this equipment.
All examples and diagrams shown in this manual are intended only as an aid to understanding the text, not to guarantee operation. VEC will accept no responsibility for actual use of the product based on these illustrative examples.

Owing to the very great variety in possible application of this equipment, you must satisfy yourself as to its suitability for your specific application.

VB-1COM Serial Interface Block

Guidelines for the safety of the user and protection of the VB-1COM Serial Interface Block

This manual provides information for the installation and use of the VB-1COM Interface Block. The manual has been written to be used by trained and competent personnel. The definition of such a person or persons is as follows;

- a) Any engineer who is responsible for the planning, design and construction of automatic equipment using the product associated with this manual should be of a competent nature, (trained and qualified to the local and national standards required to fulfill that role). These engineers should be fully aware of safety with regards to automated equipment.
- b) Any commissioning or service engineer must be of a competent nature, trained and qualified to the local and national standards required to fulfill that job. These engineers should also be trained in the use and maintenance of the completed product. This includes being completely familiar with all associated documentation for the said product. All maintenance should be carried out in accordance with established safety practices.
- c) All operators of the compliance product should be trained to use that product in a safe and coordinated manner in compliance to established safety practices. The operators should also be familiar with all documentation which is connected with the actual operation of the completed equipment.

Note: The term completed equipment refers to a third party constructed device which contains or uses the product associated with this manual.

VB-1COM Serial Interface Block

CONTENTS

1. INTRODUCTION	1-1
1.1 Outline of Product	1-1
2. SPECIFICATIONS	2-1
2.1 Appearance and Name of Each Portion	2-1
2.2 General Specifications and Performance Specifications	2-2
3. CONNECTION AND WIRING	3-1
3.1 Connection with the PC	3-1
3.2 Power Supply Wiring	3-2
3.3 Wiring of RS-232C Equipment	3-3
4. ALLOCATION OF BUFFER MEMORIES (BFMs)	4-1
4.1 BFM List	4-1
4.2 Details of Buffer Memories	4-3
5. TRANSMISSION PROGRAM	5-1
5.1 Example of sending/receiving the data of 16-bit buffer length	5-1
5.2 Example of sending/receiving the data of 8-bit buffer length	5-8
6. APPENDIX	6-1

VB-1COM Serial Interface Block

1. INTRODUCTION

The Serial Interface block VB-1COM (hereinafter referred to as "VB-1COM") is connected to the VB Series PLC to realize full duplex (RS-232C only) serial data communication with another RS-232C/RS-485 interface such as a personal computer, bar code reader, printer, etc.

1.1 Outline of Product

Applicable PC change all appropriate PC TO PLC

The VB-1COM can be connected as a special block of the VB Series PLC

Control instructions

Send/receive data is received and sent and diversified control commands are manipulated by using the FROM/TO instruction.

Number of I/O points

Connection method

The number of I/O points occupied is none. However, the capacity of the 5 V power supplied from the PC is limited.

The current consumption of the 5 V power of the VB-1COM is 40 mA. Make sure that the total current consumption of the 5 V power including other special blocks is equivalent to or less than that available.

Communication method

Full duplex (RS232C only) start-stop synchronization and non-protocol procedure are used. The communication format can be specified using the buffer memories (BFMs).

Send/receive buffer

The send/receive buffer can accommodate 512 bytes/256 words.

ASCII/HEX conversion function

The function to convert and send a hexadecimal numeric (0 to F) saved in the send data buffer as well as the function to convert a received ASCII code into a hexadecimal numeric (0 to F) and save it to the receive buffer are provided.

VB-1COM Serial Interface Block

2. SPECIFICATIONS

2.1 Appearance and Name of Each Portion

Weight : Approx. ? kg Accessory : none

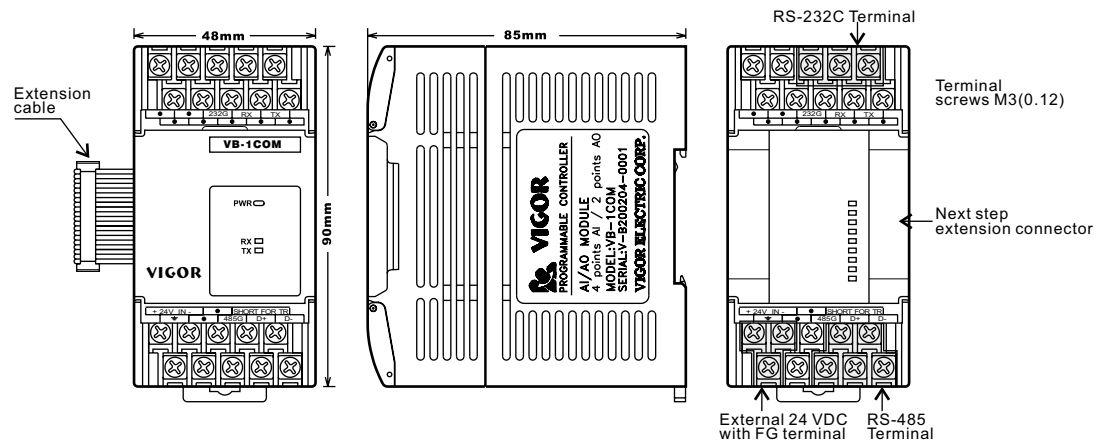

POWER LED : Lt when 5 VDC power supplied from the PLC.

SD (TXD) LED : Lt while data is sent to the RS-232C/RS485 equipment connected to the VB-1CO.

RD (RXD) LED : Lt while data is received from the RS-232C/RS485 equipment connected to the VB-1COM.

VB-1COM Serial Interface Block

2.2 Performance Specifications

Performance specifications

<i>Driving power supply</i>	24 VDC \pm 10%, ? mA
<i>Current consumption</i>	5 VDC, ? mA (supplied from PC via extension cable)
<i>Transmission standard</i>	In accordance with RS-232C, D-Sub 9-pin connector
<i>Isolation method</i>	Photocoupler isolation
<i>Transmission distance</i>	15 m or less
<i>Indication (LED)</i>	POWER, SD (TXD), RD (RXD)
<i>Communication method</i>	Full duplex start-stop synchronization, non-protocol procedure. Communication format is specified by buffer memories (BFMs).
<i>Transmission speed</i>	300, 600, 1200, 2400, 4800, 9600, 19200, 3800, 76800, 14400, 28800, 57600
<i>Applicable PC</i>	VB Series PLC
<i>Communication with PC</i>	Communication is performed by FROM/TO instruction given by PC via buffer memories. Each of send/receive buffer accommodates 256 words.

VB-1COM Serial Interface Block

3. CONNECTION AND WIRING

3.1 Connection with the PLC

Connecting the extension cable

The VB-1COM can be directly connected to the basic unit of the VB Series PLC or connected on the right side of another extension block/unit. A number is assigned to each special unit/block counting from the one nearest the basic unit in the way of No. 1 . . . No. 8. Up to eight special units/blocks in all can be connected in principle. However, the capacity of the 5 VDC power supplied from the PC is limited.

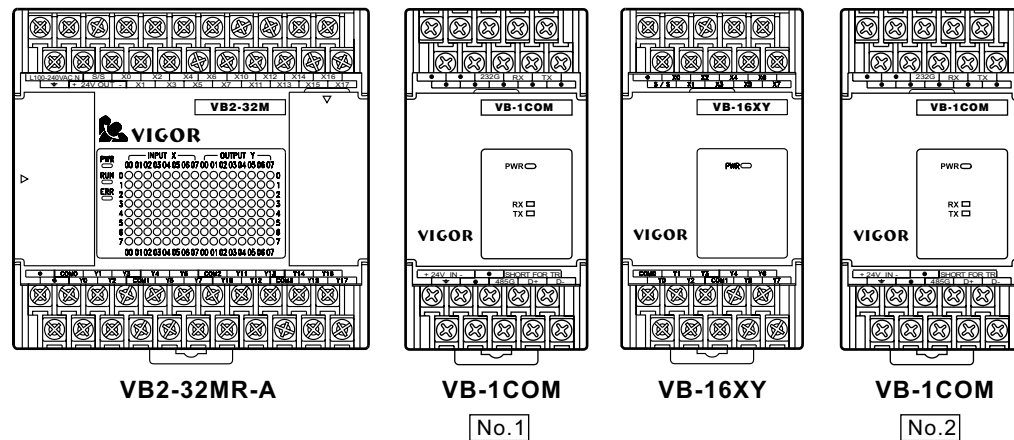

VB-1COM Serial Interface Block

3.2 Power Supply Wiring

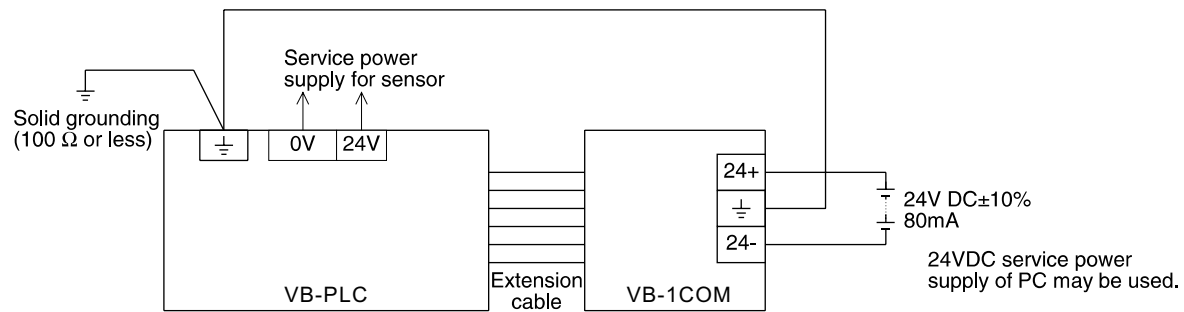

Wiring



Handling of the crimp-style terminal

Use the crimp-style terminals of the dimensions shown on the figure on the left. Make sure that the tightening torque of the terminal is 0.5 to 0.8 N (5 to 8 kgf•cm). Tighten each terminal securely to avoid malfunction.



VB-1COM Serial Interface Block

3.3 Wiring of RS-232C Equipment

Pin arrangement of communication connector

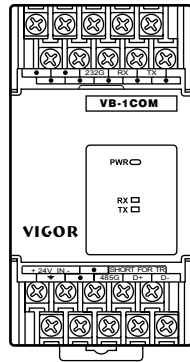

Signal name	Function	Signal direction 232IF:Counterpart equipment
RD (RXD)	Receive data (LED indication provided)	←
SD (TXD)	Send data (LED indication provided) 1	→
485 (D+)	Send data (LED indication provided) 1	↔
485 (D-)	Send data (LED indication provided) 1	↔

VB-1COM Serial Interface Block

Connection example

The signal wiring of the RS-232C equipment varies depending on the RS-232C specifications connected. Check the specifications of the RS-232C equipment used, then connect the signals correctly. Representative wiring examples are shown below.

Connection with counterpart equipment of terminal specifications BFM #0 communication format: b9 = 0, b8 = 0, without control line

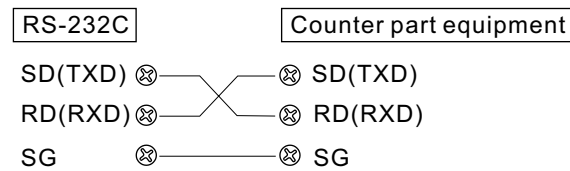

Communication is performed in accordance with the condition determined by the software in the VB-1COM and the counterpart equipment.

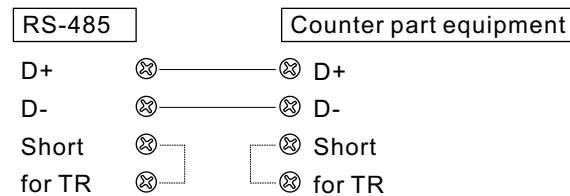

VB-1COM Serial Interface Block

4. ALLOCATION OF BUFFER MEMORIES (BFMs)

4.1 BFM List

VB-1COM data with the PLC via the buffer memories BFMs (16-bit RAM memories) in the VB-1COM. FNC78 (FROM) and FNC79 (TO) instructions are used to read and write the buffer memories.

BFM No.	Name	Setting range	Initial value	R : For read W:For write
# 0	Communication format		0087H	W
# 1	Command		0	W
# 2	Receive upper limit byte count	1 to 512 (when data length is 16 bits) 1 to 256 (when data length is 8 bits) "0" is treated as "512" or "256".	0	W
# 3	Receive time-out time	1 to 32,767 (X 10 ms) "0" eliminates time-out time.	0	W
# 4	Send header, lower 2 bytes	4 bytes max., zero suppression	0 (no header)	W
# 5	Send header, upper 2 bytes		0	
# 6	Send terminator, lower 2 bytes	4 bytes max., zero suppression	0(no terminator)	W
# 7	Send terminator, upper 2 bytes		0	
# 8	Receive header, lower 2 bytes	4 bytes max., zero suppression	0 (no header)	W
# 9	Receive header, upper 2 bytes		0	
# 10	Receive terminator, lower 2 bytes	4 bytes max., zero suppression	0(no terminator)	W
# 11	Receive terminator, upper 2 bytes		0	
# 13	Number of remaining send data	0 to 512 (when data length is 16 bits) 0 to 256 (when data length is 8 bits)	0	R
# 14	Number of receive buffers	0 to 256	0	R
# 15	Send sum result		0	R
# 16	Receive sum result		0	R

VB-1COM Serial Interface Block

BFM No.	Name	Setting range	Initial value	R:For read W:For write
# 28	Status		0	R
# 29	Error code		0	R
# 30	Model code		K7030	R
#1000	Send byte count	0 to 512 (when data length is 16 bits) 0 to 256 (when data length is 8 bits)	0	W
#1001 to #1256	Send buffers		0	W
#2000	Receive byte count	0 to 512 0 to 256	0	R
#2000 to #2256	Receive buffers		0	R

Note: Undefined BFM Nos. are not allowed to be used in the program. Trying to do so or attempt to read from the write, Only BFMs or attempt to write to the Read_Only BFMs will cause M9067 TO "ON".

*1 : Spare buffers used in the interlink connection mode

VB-1COM Serial Interface Block

4.2 Details of Buffer Memories

BFM #0: Communication format

Bit	Description	0	1	Initial value
b0	Data length	7 bit	8 bit	1 : 8 bit
b1 b2	Parity	(00) : None (01) : Odd (11) : Even		(11) : Even
b3	Stop bit	1 bit	2 bit	0 : 1 bit
b4 b5 b6 b7	Baud rate (bps)	(0011) : 300 (0100) : 600 (0101) : 1200 (0110) : 2400 (0111) : 4800 (1000) : 9600 (1001) : 19200	(1010) : 38400 (1011) : 76800 (1100) : 14400 (1101) : 28800 (1110) : 57600	(1000) : 9600 bps
b10 b11	Addition of CR and LF	(00) : Not added (01) : CR only (11) : CR and LF		(00) : Not added
b12 b13	Availability of check sum and ASCII/HEX conversion	(00) : Not available (01) : ASCII/HEX conversion available (10) : Check sum available (11) : Check sum available, ASCII/HEX conversion available		(00) : Not available
b14	Send/receive buffer data length	16 bit	8 bit	0 : 16 bit
*	Undefined (disabled)			0: Undefined

VB-1COM Serial Interface Block

The communication format is determined on the rising edge of the send/receive enable command (BFM #1 b0). Accordingly, the setting of the communication format should be preliminary transferred using the TO instruction before BFM #1 b0 is turned on. Also, the send header and the send terminator are determined in the rising edge of the send command (BFM #1 b1). The receive header and the receive terminator are determined on the rising edge of BFM #1 b0 or on the rising edge of the receive completion reset command (BFM#1 b2). Accordingly, when only the header and the terminator exclusively are changed it is not necessary to turn BFM #1 b0 off. The change becomes valid from the next send/receive operation.

Setting example of communication format (hexadecimal, constant specification)

Data length : 8 bits
 Parity : Odd
 Stop bit : 1 bit
 Baud rate : 2,400 bps
 Control line : Not used
 CR, LF : Not added
 Check sum and ASCII/HEX conversion : Not available
 Buffer data length : 8 bits

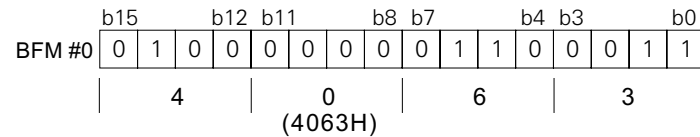

VB-1COM Serial Interface Block

Communication format list

①		Data				
②		Data	Terminator			
③		Data	Terminator	CR		
④		Data	Terminator	CR	LF	
⑤	Header	Data	Terminator	Sum		
⑥	Header	Data	Terminator	Sum	CR	
⑦	Header	Data	Terminator	Sum	CR	LF
⑧		Data	CR			
⑨		Data	CR	LF		

Select the communication format used to send/receive data in the 232IF among 9 types shown on the left.

- The header can be specified in the

--

 portion in the communication format.
- In the communication format type ①, hexadecimal data (binary) and ASCII code can be send and received.
In the communication format types ② to ⑨, the send/receive data should be any ASCII code except the header, the terminator, CR and LF.
Communication can be performed using the ASCII/HEX conversion function by specifying the BFM #0 b12.
- The ASCII codes available for the initial terminator are 01H to 1FH.

VB-1COM Serial Interface Block

- b0 to b7 (data length, parity, stop bit and baud rate):
b0 to b7 should be aligned with the communication specifications of the connected counterpart equipment.

- b11 and b 10 (addition of CR and LF):
Set these bits as follows.
 - Not added (b11 = 0, b10 = 0)
 - CR only is added. (b11 = 0, b10 = 1)
 - CR and LF are added. (b11 = 1, b10 = 1)For the CR/LF addition format, refer to the communication format list shown above.

- b13 and b12 (Availability of check sum and ASCII/HEX conversion):
Set these bits as follows.
 - Neither the check sum nor the ASCII/HEX conversion is available. (b13 = 0, b12 = 0)
 - The ASCII/HEX conversion only is available. (b13 = 0, b12 = 1)
 - The check sum only is available. (b13 = 1, b12 = 0)
 - Both the check sum and the ASCII/HEX conversion are available. (b13 = 1, b12 = 1)For the check sum addition format, refer to the communication format list shown above.

VB-1COM Serial Interface Block

When execution of the ASCII/HEX conversion is specified, the hexadecimal numeric data (0 to F) inside the send buffers (BFMs #1001 to #1256) is converted into the ASCII code, then sent. The received ASCII code is converted into hexadecimal numeric data (0 to F), then saved to the receive buffers (BFMs #2001 to #2256). At this time, the send/receive byte count indicates the number of hexadecimal data.

Send format when hexadecimal data is converted into ASCII code

Example: When the send data 10ABH, the header STX and the terminator ETX are sent

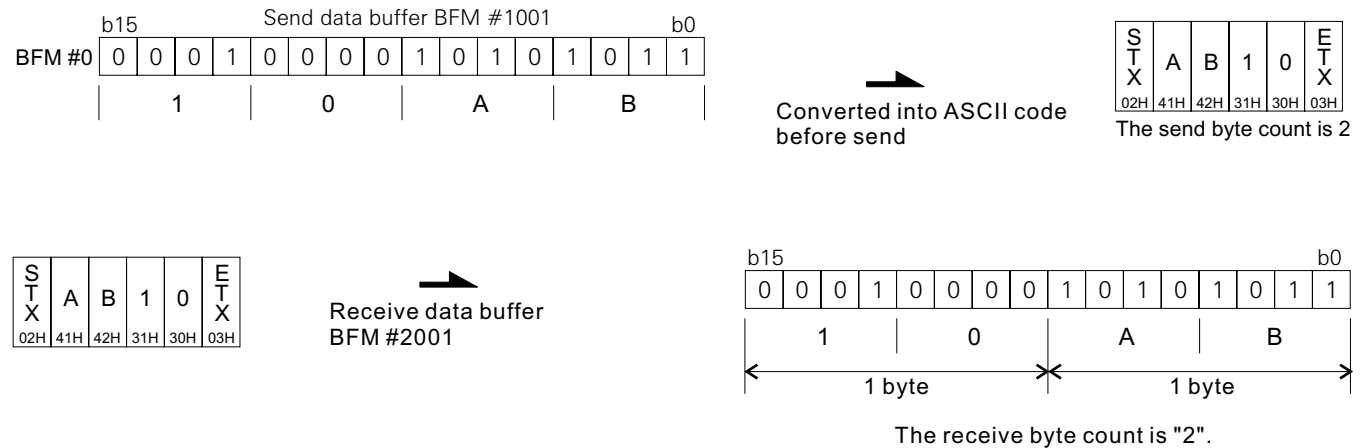

VB-1COM Serial Interface Block

- **b14** (send/receive buffer data length):
The data is treated as follows in accordance with the buffer data

- In the case of 16 bits (b14 = 0)

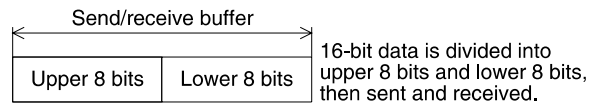

Example of send buffers

S	BFM	BFM	BFM	BFM	E
T	#1001	#1001	#1002	#1002	T
X	lower	upper	lower	upper	X

- In the case of 8 bits (b14

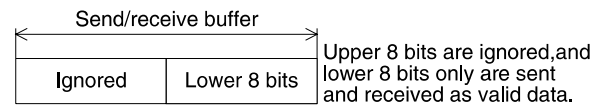

Example of send buffers

S	BFM	BFM	BFM	BFM	E
T	#1001	#1002	#1003	#1004	T
X	lower	lower	lower	lower	X

VB-1COM Serial Interface Block

BFM #1: Command

Bit	Description
b0	Send/receive enable (ER ON)
b1	Send command
b2	Receive completion reset command
b3	Error reset

BFM #1 gives the command for send/receive and the status information reset command to the VB-1COM.

- **b0 (send/receive enable):**

While b0 is turned on, the VB-1COM can send and receive data.

The contents of the following setting items are determined on the rising edge of b0. Make sure to set the contents using the TO instruction before setting b0 to ON .

- BFM #0 (communication format)
- BFM #9 and #8 (receive header)
- BFM #11 and #10 (receive terminator)

On the rising edge of b0, the error occurrence (BFM #28 b3) and the error code (BFM #29) are cleared.

- **b1 (send command):**

On the rising edge of b1, the contents of the send buffers (BFMs #1001 to #1256) are sent to the counterpart equipment up to the send byte count (BFM #1000).

When send is completed, the send completion status (BFM #28 b0) is set. BFM #28 b0 is automatically reset when the next send command (b1) is given.

When b1 is given, the contents of the following setting items are determined.

- BFM #5 and #4 (send header)
- BFM #7 and #6 (send terminator)

VB-1COM Serial Interface Block

- b2 (receive completion reset command):

When b2 is set to ON , the following items are cleared.

- BFM #28 b1 (receive completion)
- BFM #2000 (receive byte count)
- BFM #2001 to #2256 (receive buffers)

When receive is completed, b2 should be set to ON to clear the receive completion status (BFM #28 b1). If BFM #28 b1 is not reset, the next data cannot be received.

When b2 is set to ON , the contents of the following setting items are determined.

- BFM #9 and #8 (receive header)
- BFM #11 and #10 (receive terminator)

- b3 (error reset):

When b3 is set to ON , the error occurrence status (BFM #28 b3) and error code (BFM #29) are cleared.

VB-1COM Serial Interface Block

BFM #2: Receive upper limit byte count

Setting range 1 to 512 (when buffer data length is 16 bits)

1 to 256 (when buffer data length is 8 bits)

"0" is regarded as "512" or "256". The initial value is "0".

BFM #2 specifies the maximum byte count received by the VB-1COM.

When data is received up to the receive upper limit byte count, the receive completion status (BFM #28 b1) is set.

When the receive terminator (BFMs #11 and #10) or the receive time-out time (BFM #3) is set and the set condition is satisfied, it is regarded that receive is completed even if the data received is within the receive upper limit byte count.

BFM #3: Receive time-out time

Setting range 1 to 32, 767 (x 10 ms)

"0" eliminates time-out time. The initial value is "0".

BFM #3 specifies the receive data waiting time limit.

When the next data is not received within the receive time-out time starting from the receive edge of each data, the receive time-out flag (BFM #28 b2) is set to ON, it is regarded that receive is completed, and the receive completion status (BFM #28 b1) is set.

VB-1COM Serial Interface Block

BFMs #5 (upper) and #4 (lower): Send header

Setting range 4 bytes maximum, zero suppression

The initial value is "0" (not provided).

For the send data of the VB-1COM, 4 headers maximum can be specified. When the number of headers is less than 4, the upper "0"s are ignored (zero suppression) and not transferred.

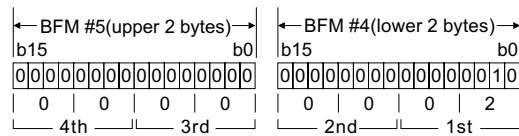

Example:02H(STX)

- The transmission order is fourth header, third header, second header, first header when 4 headers are specified.

BFMs #7 (upper) and #6 (lower): Send terminator

Setting range 4 bytes maximum, zero suppression

The initial value is "0" (not provided).

For the send data of the VB-1COM, 4 terminators maximum can be specified. When the number of terminators is less than 4, the upper "0"s are ignored (zero suppression) and not transferred.

As the first terminator, specify an ASCII code from 01H to 1FH. (As the second to fourth terminators, any ASCII code can be specified.)

The register structure and the transmission order are equivalent to those of the send header described above.

VB-1COM Serial Interface Block

BFBs #9 (upper) and #8 (lower): Receive header

Setting range 4 bytes maximum, zero suppression
The initial value is "0" (not provided).

For the receive data of the VB-1COM, 4 headers maximum can be specified. When the number of headers is less than 4, the upper "0"s are ignored (zero suppression).

The register structure and the transmission order are equivalent to those of the send header described above.

BFBs #11 (upper) and #10 (lower): Receive terminator

Setting range 4 bytes maximum, zero suppression
The initial value is "0" (not provided).

For the receive data of the 232IF, 4 terminators maximum can be specified. When the number of terminators is less than 4, the upper "0"s are ignored (zero suppression).

As the first terminator, specify an ASCII code from 01H to 1FH. (As the second to fourth terminators, any ASCII code can be specified.)

The register structure and the transmission order are equivalent to those of the send header described above.

VB-1COM Serial Interface Block

BFM #13: Number of remaining send data

Saved value 0 to 512 (when buffer data length is 16 bits)

0 to 256 (when buffer data length is 8 bits)

The send byte count (BFM #1000) reduced by the number of data actually sent is during transmission.

BFM #14: Number of receive buffers

Saved value 0 to 256

The number of buffers which have actually received data is saved in turn with regard to the receive buffers BFM #2001 to #2256

VB-1COM Serial Interface Block

BFM #15: Send sum result

Initial value 0

The check sum value added to the send data is saved.
The sum check target range and the calculation method are shown below.

Sum check target range and calculation method

Example:

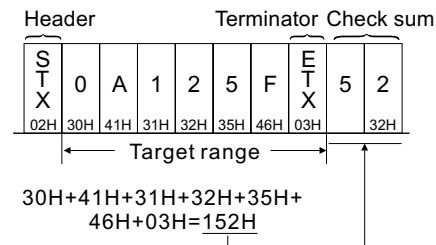

The total value including the terminator and excluding the header is calculated. Then, the lower1 byte is converted into the ASCII code, and sent or received. The data converted into the ASCII code is placed in the order of upper digit and lower digit.

The check sum mechanism is still available in 8 databit and no doing ASCII conversion So, the format of value of check sum is saved as Hexdecimal.

VB-1COM Serial Interface Block

BFM #16: Receive sum result

Initial value: 0

The sum check value of the receive data is saved. as HEX format in spite of whether doing ASCII conversion.

When the check sum added to the receive data is different from the receive sum result, receive sum check error occurs.

The sum check target range and the calculation method are equivalent to those for the send sum result described above.

VB-1COM Serial Interface Block

Bit	Description
b0	Send completion
b1	Receive completion
b2	Receive time-out
b3	Error occurrence
b5	Undefined
b6	Being sent
b7	Being received

The VB-1COM status and the send/receive result are saved as status information. This information can be read from the PC using the FROM instruction, then utilized.

- **b0 (send completion)**
When send of data up to the send byte count (BFM #1000) is completed, the send completion status (b0) is set. The send completion status (b0) is automatically reset when the next send command (BFM #1 b1) is set to ON .
- **b1 (receive completion)**
When receive of data up to the receive upper limit byte count (BFM #2) is completed, the receive completion status (b1) is set. If the receive terminator (BFMs #11 and #10) or the receive time-out time (BFM#3) is set, it is regarded that receive is completed
when the set condition is satisfied, then the receive completion status (b1) is set in the same way.
This status is required to be reset using the sequence program. If it is not reset, the next data cannot be received. This status can be reset using the receive completion reset command (BFM #1 b2).

VB-1COM Serial Interface Block

- b2 (receive time-out)
When the receive time-out time (BFM #3) is reached while data is received, the receive time-out status (b2) is set. At the same time, the receive completion status (b1) is also set.
This status is automatically reset when the receive completion reset command (BFM #1 b2) is executed.
- b3 (error occurrence)
When an error occurs while data is sent or received, b3 is set to ON and the error is saved to the error code (BFM #29).
- b6 (being sent)
b6 is turned on after the send command (BFM #1 b1) is given until the send completion status (BFM #28 b0) is set.
- b7 (being received)
b7 is turned on after the first char is received until the receive completion status (BFM #28 b1) is set.

VB-1COM Serial Interface Block

BFM #29: Error code

Code	Description	Causes and countermeasures
0	No error	—
1	Receive parity error, overrun error, framing error	Communication format such as baud rate is not matched. Control timing is not matched.
2	Undefined	—
3	Defective receive character	Receive data is not ASCII code.
4	Receive sum check error	Receive sum is not equal calculated sum result (BFM #16).
5	Undefined	Receive byte count exceeds 512 +30 bytes. Decrease receive upper byte count (BFM #2), and increase spare receive buffer area.
6	Baud rate setting error	Non-existing baud rate is specified.
7	Receive CR error	CR is not placed in correct position.
8	Receive LF error	LF is not placed in correct position.
9	Send/receive initial terminator setting error	Initial terminator is other than 01H to 1FH.
10	Receive terminator error	Receive terminator is not placed in correct position or not matched.
11	Undefined	—

VB-1COM Serial Interface Block

BFM #30: Model code

The model code of the VB-1COM is "K7030".

The model code is a fixed code assigned to each special extension equipment handled by the FROM/TO instruction. The PLC can distinguish the equipment type by reading this code.

BFM #1000: Send byte count

Setting range 0 to 512 (when buffer data length is 16 bits)

0 to 256 (when buffer data length is 8 bits)

The BFM #1000 specifies how many bytes out of 512 bytes/256 words in the 16-bit send buffers (BFMs #1001 to #1256) are to be sent.

BFMs #1001 to #1256: Send buffers

Each of them is a 16-bit buffer to save the send data, and accommodates 512 bytes/256 words.

VB-1COM Serial Interface Block

BFM #2000: Receive byte count

Saved value 0 to 512 (when buffer data length is 16 bits)
0 to 256 (when buffer data length is 8 bits)

The byte count received from the counterpart equipment is saved.
This value is cleared by the receive completion reset command (BFM #1 b2).

BFMs #2001 to #2256: Receive buffers

Each of them is a 16-bit buffer to save the data received from the counterpart equipment, and accommodates 512 bytes/256 words. The buffer structure is equivalent to that of the send buffers.
The receive contents are cleared by the receive completion reset command (BFM #1 b2).

VB-1COM Serial Interface Block

5. TRANSMISSION PROGRAM

5.1 Example of sending/receiving the data of 16-bit buffer length

This paragraph describes an example in which data of 16-bit buffer length is sent and received between the equipment of the terminal specifications. In this example, the ASCII code saved in the data registers D201 to D205 in the PLC is sent to the counterpart equipment, and the data received from the counterpart equipment is saved to the data registers D301 to D304 in the PLC.

System configuration

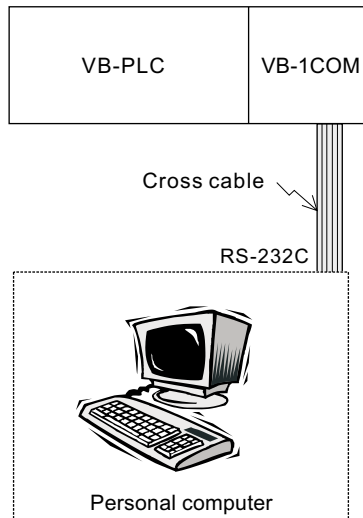

VB-1COM Serial Interface Block

Setting example of buffer memories (The items not described here are set to the initial value respectively.)

BFM #0: Communication format

Bit	Description	Setting
b0	Data length	(1): 8 bits
b1 b2	Parity	(1, 1): Even
b3	Stop bit	(1): 2 bits
b4 b5 b6 b7	Baud rate	(1001): 19200 bps
b8 b9	Control line	(0, 0): Not used
b10 b11	Addition of CR and LF	(0, 0): Not added
b12 b13	Availability of check sum and ASCII/HEX conversion	(0, 0): Not available
b14	Send/receive buffer data length	(0): 16 bits
b15	Undefined	—

← Specification item for 16-bit length

b15	b8	b7	b0
0	0	0	1
0	0	0	1
0	0	1	1
0	1	1	1
0	1	1	1
0	9	F	(009FH)

VB-1COM Serial Interface Block

BFM #1: Command

M0→b0: Send/receive enable (ER ON)
M1→b1: Send command
M2→b2: Receive completion reset command
M3→b3: Error reset

BFM #2: Receive upper limit byte count

8 bytes

BFMs #4 to #11: Header and terminator

BFMs #4 and #8 (send/receive header): 02H (STX)
BFMs #6 and #10 (send/receive terminator): 03H (ETX)

BFM #28: Status

b0→M10: Send completion
b1→M11: Receive completion
b2→M12: Receive time-out
b3→M13: Error occurrence
b4→M14: Receive suspended
b5→M15: Undefined
b6→M16: Being sent
b7→M17: Being received

b8~b15: Undefined

BFM #1000: Send byte count

9 bytes

VB-1COM Serial Interface Block

BFMs #1001 ~: Send buffers

Nine-byte send data "123456789" is prepared in ASCII code in accordance with the send byte count specified above.

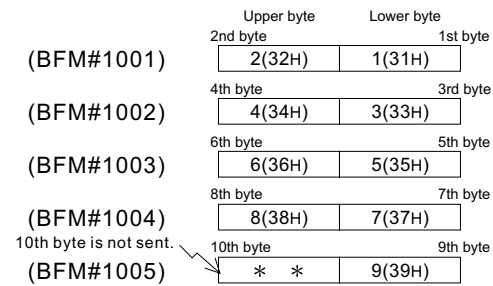

BFMs #2001 ~: Receive buffers

Eight-byte receive data specified in accordance with the receive upper limit byte count (BFM #2) is read to the data registers D301 to D304 in the PLC.

VB-1COM Serial Interface Block

Example of sequence program

VB-1COM Serial Interface Block

Operation chart

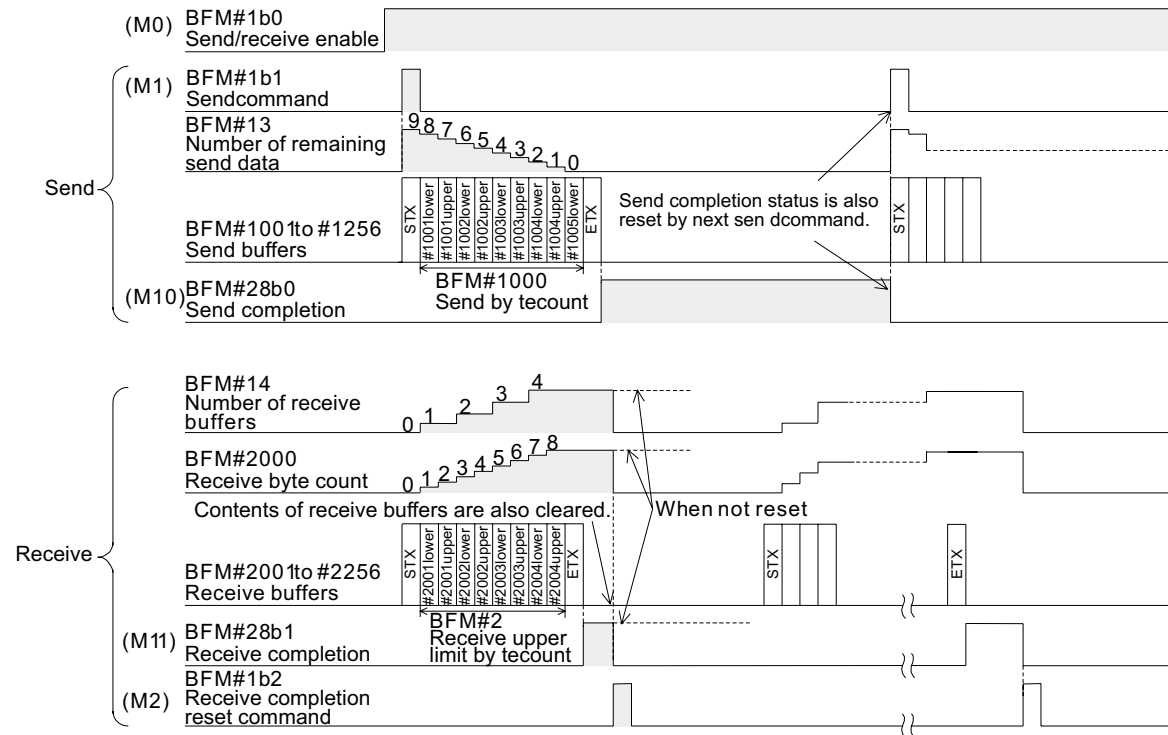

VB-1COM Serial Interface Block

5.2 Example of sending/receiving the data of 8-bit buffer length

This paragraph describes an example in which data of 8-bit buffer length is sent and received between the equipment of the terminal specifications. In this example, the ASCII code saved in the data registers D201 to D209 in the PLC is sent to the counterpart equipment, and the data received from the counterpart equipment is saved to the data registers D301 to D308 in the PLC.

System configuration

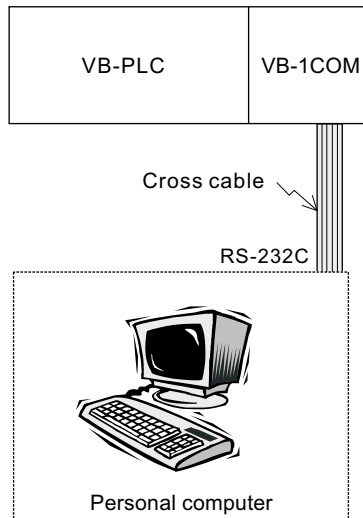

VB-1COM Serial Interface Block

Setting example of buffer memories (The items not described here are set to the initial value respectively.)

BFM #0: Communication format

Bit	Description	Setting
b0	Data length	(1): 8 bits
b1 b2	Parity	(1, 1): Even
b3	Stop bit	(1): 2 bits
b4 b5 b6 b7	Baud rate	(1001): 19200 bps
b8 b9	Control line	(0, 0): Not used
b10 b11	Addition of CR and LF	(0, 0): Not added
b12 b13	Availability of check sum and ASCII/HEX conversion	(0, 0): Not available
b14	Send/receive buffer data length	(0): 8 bits
b15	Undefined	—

← Specification item for 8-bit length

b15	b8	b7	b0
0	0	0	1
0	0	0	1
0	0	1	1
0	1	1	1
0	1	1	1
0	9	F	(409FH)

VB-1COM Serial Interface Block

BFM #1: Command

M0→b0: Send/receive enable (ER ON)
M1→b1: Send command
M2→b2: Receive completion reset command
M3→b3: Error reset

BFM #2: Receive upper limit byte count

8 bytes

BFMs #4 to #11: Header and terminator

BFMs #4 and #8 (send/receive header): 02H (STX)
BFMs #6 and #10 (send/receive terminator): 03H (ETX)

BFM #28: Status

b0→M10: Send completion
b1→M11: Receive completion
b2→M12: Receive time-out
b3→M13: Error occurrence
b4→M14: Receive suspended
b5→M15: Undefined
b6→M16: Being sent
b7→M17: Being received

b8~b15: Undefined

BFM #1000: Send byte count

9 bytes

VB-1COM Serial Interface Block

BFMs #1001 ~: Send buffers

Nine-byte send data "123456789" is prepared in ASCII code in accordance with the send byte count specified above.

	Upper byte	Lower byte	
(BFM#1001)	Ignored	1(30H)	1 byte
(BFM#1002)	Ignored	2(31H)	2 byte
(BFM#1003)	Ignored	3(32H)	3 byte
(BFM#1004)	Ignored	4(33H)	4 byte
(BFM#1005)	Ignored	5(34H)	5 byte
(BFM#1006)	Ignored	6(35H)	6 byte
(BFM#1007)	Ignored	7(36H)	7 byte
(BFM#1008)	Ignored	8(37H)	8 byte
(BFM#1009)	Ignored	9(38H)	9 byte

BFMs #2001 ~: Receive buffers

Eight-byte receive data specified in accordance with the receive upper limit byte count (BFM #2) is read to the data registers D301 to D304 in the PC.

VB-1COM Serial Interface Block

Example of sequence program

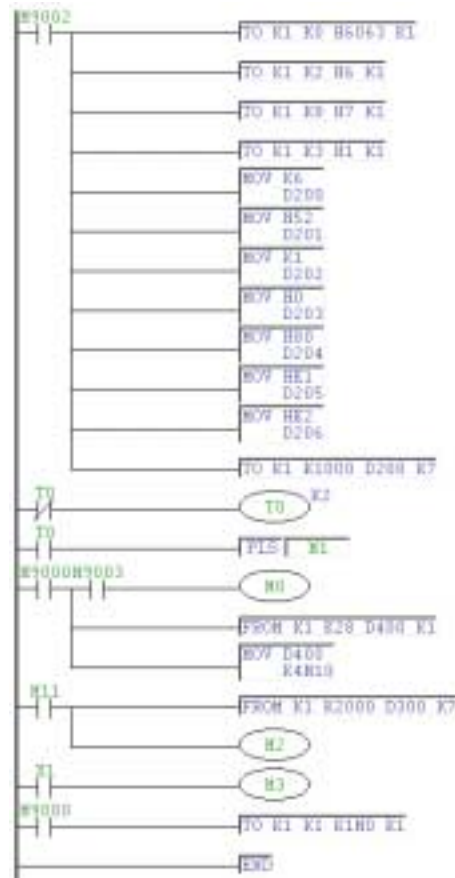

BFM #0 : H6063 value for communication format setting
 8 DataBit, Parity:Odd, 1 Stop, 2400, CheckSun, BFM : 8 bit
 BFM #2 ByteCount of Receive Upper limit --> 6
 (NOTE ! Data area only, NOT including Header, Terminator or CheckSum)
 BFM #8 Receive Header --> 07H

BFM #3 assign TimeOut to 10ms, dependent with BaudRate

D200 : ByteCount to send --> 6

D201 : CMD --> Read --> 'R' --> H52

D202 : ID --> 1

D203 : CH --> 非任意值 --> 取 0

D204 : ADDR --> the address of PV --> H80

D205 : Data1 --> any value when Reading --> 取 E1

D206 : Data2 --> any value when Reading --> 取 E2

Send command 'Read PV' protocol every 0.2 second

---> Customer can use methods your own.

M11 'ON' when Receive completion
 The PV can be monitored on D305(MSB) and D306(LSB)

X1 'ON' for clear the Error of 232IF

send command to BFM #1 of VB-1Com

VB-1COM Serial Interface Block

Operation chart

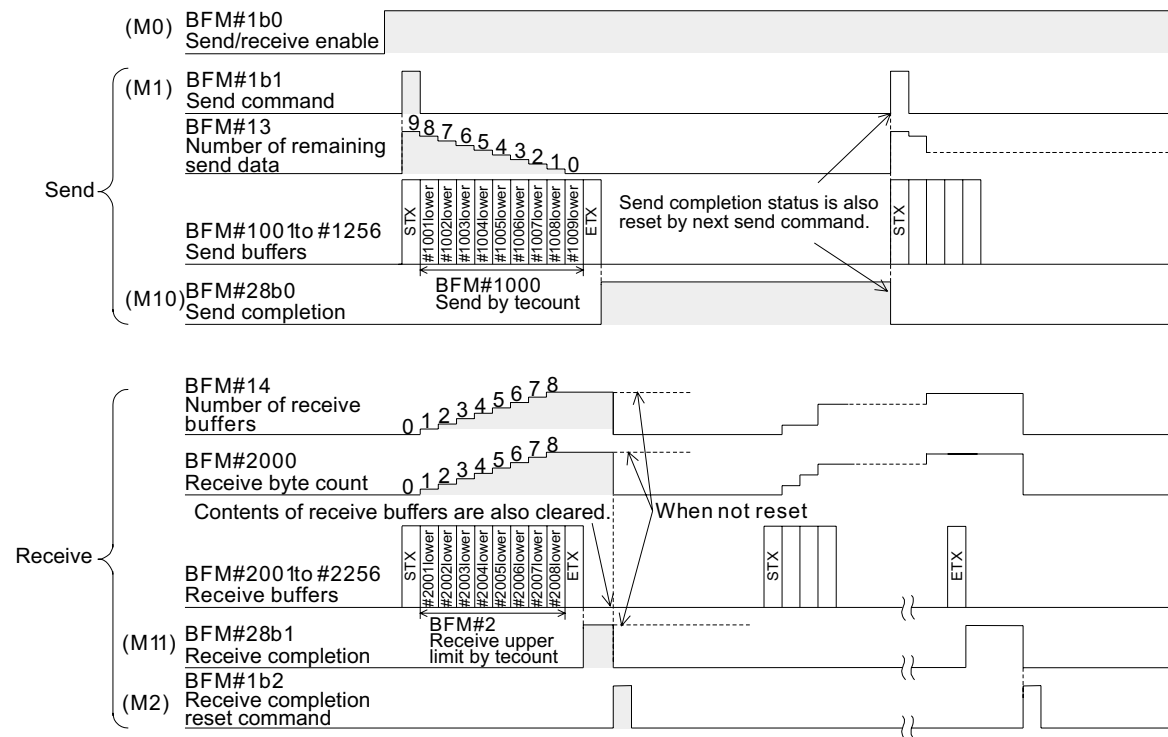

VB-1COM Serial Interface Block

6. APPENDIX

ASCII code table

HEX	0	1	2	3	4	5	6	7
0		DLE	SP	0	@	P	'	p
1	SOH	DC1	!	1	A	Q	a	q
2	STX	DC2	"	2	B	R	b	r
3	ETX	DC3	#	3	C	S	c	s
4	EOT	DC4	\$	4	D	T	d	t
5	ENQ	NAK	%	5	E	U	e	u
6	ACK	SYN	&	6	F	V	f	v
7	BEL	ETB	,	7	G	W	g	w
8	BS	CAN	(8	H	X	h	x
9	HT	EM)	9	I	Y	i	y
A	LF	SUB	*	:	J	Z	j	z
B	VT	ESC	+	;	K	[k	{
C	FF	FS	,	<	L	\	l	
D	CR	GS	-	=	M]	m	}
E	SO	RS	.	>	N	^	n	~
F	SI	US	/	?	O	_	o	DEL

VB-1COM Serial Interface Block

ASCII code table

Decimal	ASCII (hexadecimal)
0	30
1	31
2	32
3	33
4	34
5	35
6	36
7	37
8	38
9	39

Code	ASCII (hexadecimal)
STX	02
ETX	03

Alphabet	ASCII (hexadecimal)	Alphabet	ASCII (hexadecimal)
A	41	N	4E
B	42	O	4F
C	43	P	50
D	44	Q	51
E	45	R	52
F	46	S	53
G	47	T	54
H	48	U	55
I	49	V	56
J	4A	W	57
K	4B	X	58
L	4C	Y	59
M	4D	Z	5A

VB-1COM Serial Interface Block

Outline of FROM/TO command

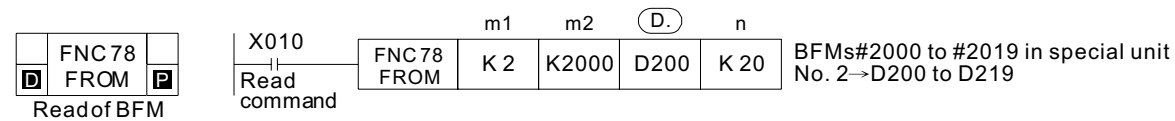

- m1 : Special unit/block No.(K1 to K8 from the one nearest the basic unit)
- m2 : Head specification No. in BFM (m2 =K0 to K32 , 766)
- (D.) : Head element No. in transfer destination. Either one can be selected among T, C, D, KnM, KnYKnS, V and Z.
The element No. can be modified using the index.
- n : Number of transfer points (n = K1 to K32, 767)

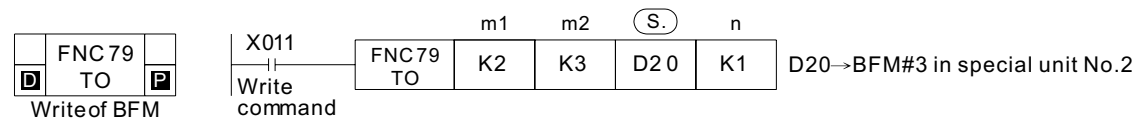

- m1, m2, n : Same as above
- (S.) : Head element No. in transfer source. Either one can be selected among T, C, D, KnX, KnM, KnY, KnS, V, Z, K and H.
The element No. can be modified using the index.

- When X010 and X011 are turned off, transfer is not executed.
- When a large quantity of data is read/written using the FROM/TO instruction, the watch dog timer (D8000) in the PLC should be rewritten to a large value.